

Dartron
Salem, Oregon 97309

Issuing Entity:
Dartron Industries, Inc

P. O. Box 13114

Phone: 503-362-2341

Fax: 503-362-2536

www.dartronrides.com

Bulletin # PI-03040K-01

Release Date: April 7, 2003

Effective Date: April 7, 2003

Supercedes: N/A

Completion Date: None

Page 1 of 2

PRODUCT IMPROVEMENT

Ride Manufacturer: Dartron Industries, Inc.	Affected Production Dates: Apply as necessary
Ride Name: Cliff Hanger	Affected Serial #'s Apply as necessary
Model #	

Abstract of Issue: Some Cliff Hanger rides have experienced a squeek noise from the car hanger block shaft and bushings. This bulletin discusses a method to lubricate the hanger block shaft if necessary.

Reason for release: The squeak noise is not detrimental to the Cliff Hanger ride. This bulletin is intended to assist those who choose to eliminate the noise.

Action to be taken:

See attached diagram.

Detail of issue:

See attached diagram.

CLIFFHANGER

LUBRICATION OF UPPER AND LOWER HANGER BLOCK PINS

STEP I:

Use the previously installed 1/4" roll pins as ports to inject lubricant onto the upper hanger block shaft. Lubricate shaft with any chain guard lubricant that is clear and non-foaming. Lubricant should be similar to Maxima Products Chain Guard which is used for chain care. Using the plastic nozzle extension, spray lubricant into roll pins while rotating the hanger block on its shaft.

UPPER HANGER BLOCK

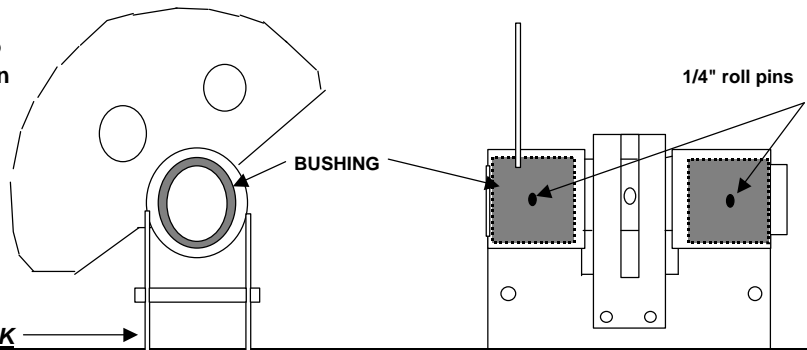

STEP II:

To lubricate the lower hanger block shaft a 1/4 roll pin must be installed. To install the roll pin follow the instructions below:

- 1 Remove safety strap held in place with 2 bolts.
- 2 Disconnect shock absorber from lower hanger block.
- 3 Remove hanger block shaft by removing the snap ring and the cotter pin. Remove the hanger block shaft. Remove the lower hanger block.
- 4 Drill 1/4" hole thru the lower hanger block shaft tube and thru its bushing. Drill hole 1" from edge and centered. Inert roll pin and re-install lower hanger block.

LOWER HANGER BLOCK

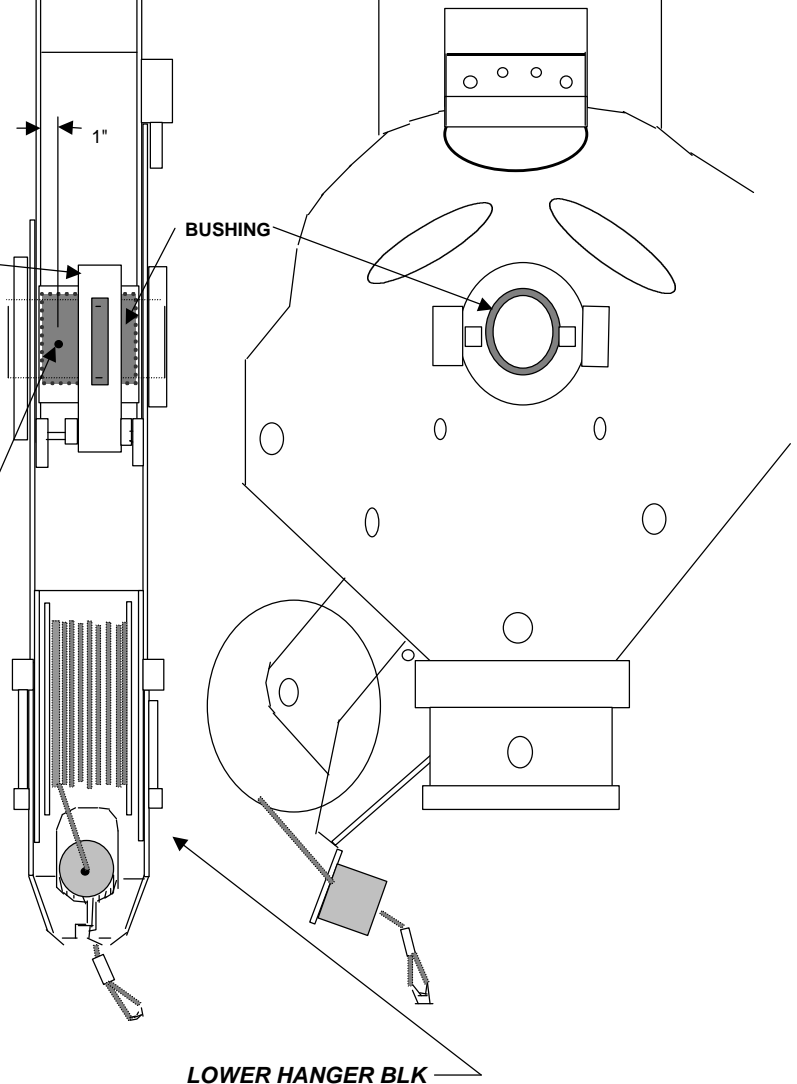

STEP III:

Use the previously installed 1/4" roll pin as a port to inject lubricant onto the lower hanger block shaft. Lubricate shaft with any chain guard lubricant that is clear and non-foaming. Lubricant should be similar to Maxima Products Chain Guard which is used for chain care. Using the plastic nozzle extension, spray lubricant into roll pin while rotating the hanger block on its shaft.