

*Dartron*

**Issuing Entity:**  
Dartron Industries, Inc  
**P. O. Box 13114**  
**Salem, Oregon 97309**  
**Phone: 503-362-2341**  
**Fax: 503-362-2536**

[www.dartronrides.com](http://www.dartronrides.com)

**Bulletin # BU-4630**

**Release Date: July 7, 1994**

**Effective Date: July 7, 1994**

**Supersedes: None**

**Completion Date: N/A**

**Page 1 of 2**

## SAFETY BULLETIN

Ride Manufacturer: Dartron Industries, Inc.

Affected Production Dates: 1991-1993

Ride Name: StarTrooper

Affected Serial #'s: 111141-5S, 206161-5S,  
210091-5S, 210211-5S, 210301-5S, 212071-5S,  
212081-5S, 301181-5S, 302031-5S, 302051-5S

Model #

**Abstract of Issue:** StarTrooper Lightning Bolt Sweep Light Cans.

**Reason for release:** Because of a combination of factors, among them rough road conditions, one area of the StarTrooper lightning bolt sweep light cans is receiving a higher degree of stress than was expected. This can result in the partial failure of the welded joints, which could cause a lightning bolt to come off the ride during transportation or operation

**Action to be taken:** Dartron Industries, Inc requires that all StarTrooper's with serial #'s shown above inspect lightning bolt sweep light cans for structural cracks as shown in (fig 1). It is further recommended that all affected lightning bolt sweep light cans be reworked with the following reinforcement kit for added rigidity.

**Parts required:**

12	Gussets	5 3/8 x 13	#4630A
12	Gussets	4 5/8 x 13	#4630B
12	Gussets	3 3/4 x 6	#4630C
240	3/8 x 1 1/4	Hex Head Cap Screws	
264	3/8	Lock washers	
240	3/8	Nuts	
24	3/8 x 3/4	Hex Head Cap Screws	
540		Flat Washers	

Bulletin # 4630

Release Date: July 7, 1994

Page 2 of 2

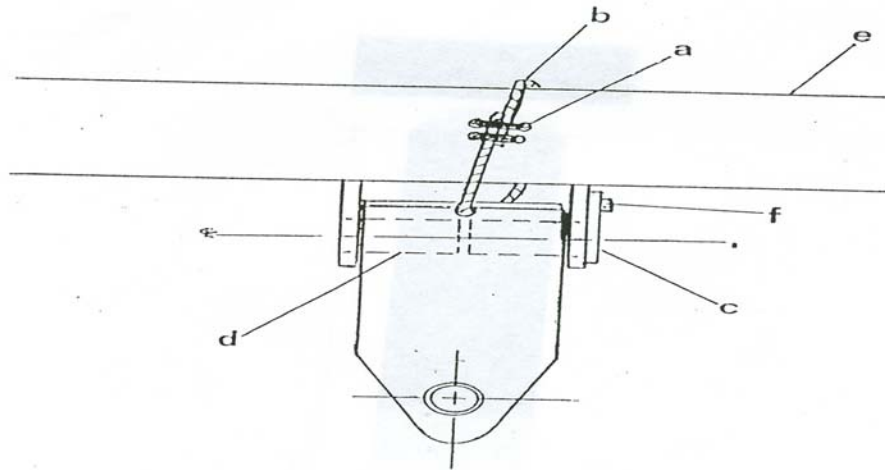

- A. TIMBLE CLAMP
- B. SAFETY CABLE
- C. HANGER BLOCK PIN
- D. HANGER BLOCK
- E. BOW
- F. HANGER BLOCK PIN BOLT