

Dartron

Issuing Entity:
Dartron Industries, Inc

P. O. Box 13114
Salem, Oregon 97309
Phone: 503-362-2341
Fax: 503-362-2536

www.dartronrides.com

Bulletin # PIB-5K-0204-001

Release Date: February 27, 2004

Effective Date: February 27, 2004

Supersedes: N/A

Completion Date: N/A

Page 1 of 6

PRODUCT INFORMATION BULLETIN

Ride Manufacturer:	Dartron Industries, Inc.	Affected Production Dates:	All Cliff Hangers
Ride Name:	Cliff Hanger	Affected Serial #'s:	All
Model #	All Cliff Hangers		

Abstract of Issue: On January 17, 2004, an incident occurred on a Cliff Hanger ride operating in Florida. As a result of the incident, Dartron required Cliff Hanger ride owners to cease operation of Cliff Hangers until they complied with the requirements of Dartron Safety Bulletin SR-5K-002. Additionally, the US Consumer Product Safety Commission recommended that Cliff Hanger rides not be operated until their investigation was complete. On February 27, 2004, CPSC accepted Dartron's Action Plan and approved Cliff Hanger rides to operate but only upon approval by Dartron of measures taken by the owners/operators in accordance with Dartron Bulletins SR-5K-002, 003, and 004 (see www.dartronrides.com).

Reason for release: To inform Cliff Hanger owners/operators, inspectors and State authorizing authorities of Dartron requirements that must be met before a Cliff Hanger ride can operate. Page 2, 3, 4 and 5 of this bulletin provide a guide for inspecting the Cliff Hanger car suspension components.

Action to be taken: Before a Cliff Hanger ride is allowed to operate, it must comply with the following:

1. The owner/operator must present a Dartron-approved Safe To Operate form (see page 6). The Dartron Safe To Operate Form verifies that the Cliff Hanger complies with Dartron requirements including NDT inspection and that the structural integrity of the gusset joint has not been compromised. It also verifies that a Dartron-approved back-up device is in place. These requirements are found in Safety Bulletins SR-5K-002 and SR-5K-003.
2. Car hangers must be capable of insertion into lower hanger blocks without force, and by April 1, 2004, all Cliff Hangers must have car rack pins cabled to rack turnbuckles (see Bulletin # SR-5K-004).
3. When the Cliff Hanger meets the requirements of numbers 1 and 2 above, it is approved to operate. The Cliff Hanger can be inspected to the drawings attached as Pages 2, 3, 4 and 5 of this bulletin. Any configuration shown is approved if installed correctly and not showing any indications of distress.

Detail of issue: Page 2, 3, 4 and 5 provide inspection guides for approved back-up devices and approved gusset joint configurations. Page 6 is a sample Dartron Safe To Operate form.

PASSENGER CARRIER INSPECTION GUIDE

1. CHECK PASSENGERS RETAINING MAIN HANGER BLOCK. CHECK FOR 10 POINTS OF BOLT TORQUE. CHECK FOR DEFECTS AND REPAIRS.
2. CHECK LOWER BOWTIE OR SWAYBEAM AS APPLICABLE. CHECK FOR REMOVABLE PINS. EXAMINE TO SEE THAT PINS ARE CORRECT TYPE AND ALL INSTALLED IN CORRECT MOUNTING POINTS. LOWER HANGER BLOCK.
3. CHECK BOLTS & NUTS ON UPPER & LOWER HANGER BLOCKS TO BE CERTAIN THAT FASTENERS ARE INSTALLED CORRECTLY.
4. CHECK LOWER HANGER BLOCK FOR TWO FASTENERS BEHIND PIN & PULL POINT.
5. CHECK CAP STEM TO HANGER BLOCK FOR BUSH. CHECK FOR CRACKS. PIN & PULL WELD IN PLACE & BUSH NOT BROKEN OFF.
6. CHECK BUSHES TO FIT IN CAP STEM & STEM TO CAP BUSH. BUSHES MUST BE VERIFIED THAT ARE SAFE & NOT HAVE NOT BROKEN OFF.
7. CHECK CAP STEM WELD ON CAP FRAME & WELD TO HANGER BLOCK ARE IN PLACE & SECURED.
8. EXAMINE PIVOT POINT FOR REMAINS TO BE REMOVED. MAKE ALL CHECKS ARE SATISFACTORY. HINGERS ARE SECURED IN PLACE.
9. CHECK CAR HANDLE PIN TO INSURE PINS IS SHIPPED IN PLACE.
10. EMPTY CAR IS THREADED THROUGH BOTH TUBES OF CAP STEM & TIGHTEN TO CAP FRAME.

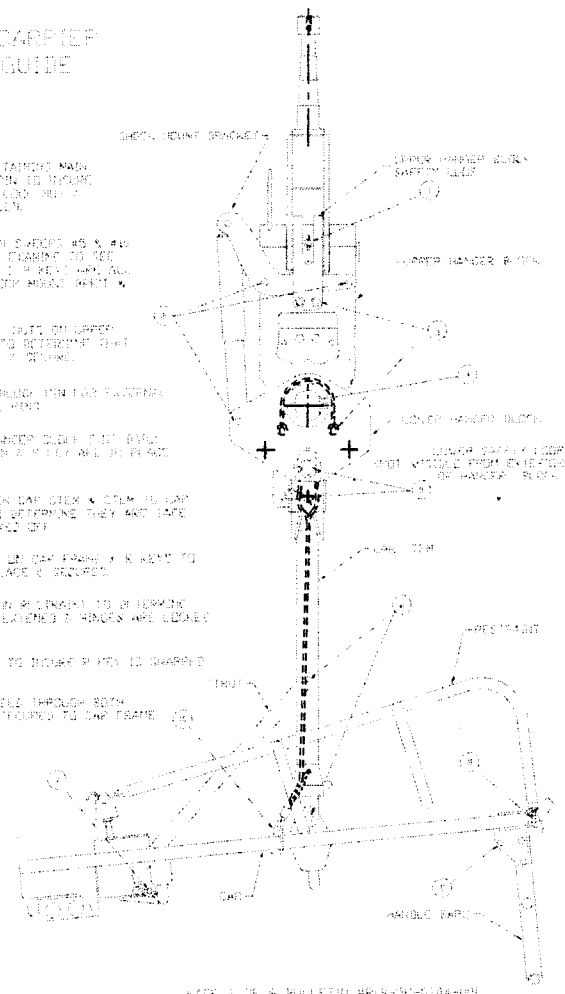

1

2

3

Dartron Industries, Inc.

In accordance with Safety Bulletin # SR-5K-002 Dartron has received a NDT Magnetic Particle and a Back Up Device Report for Cliff Hanger Serial Number _____.

The Mag Particle Report provided the below information about the gusset to Stem joint:

Gusset Joint Uncompromised on car: 1 2 3 4 5 6 7 8 9 10 none

Allowable defects were found on cars: 1 2 3 4 5 6 7 8 9 10 none

Action Required _____

Action Required _____

Action Required _____

Rejected car hanger stems were found on cars:

1 2 3 4 5 6 7 8 9 10 None

Rejected car hangers must be replaced with a new car hanger purchased from Dartron Industries.

Summary of NDT action taken:

Successfully Completed Inspection: _____

Rejected: _____ Status of Rejected Stems: _____

Summary of Back Up device installation:

Original Cable _____

Retrofit Strap _____

Information provided by: _____

Cliff Hanger S/O # _____ owned by _____ complied with the NDT and backup device requirements of Safety Bulletin # SR-5K-002 on the date of _____ and is determined by Dartron Industries, Inc. to be safe to operate.

J. Robert Coil – President
Dartron Industries, Inc.