

BOLLIGER & MABILLARD

CONSULTING ENGINEERS INC.

Ch. des Dailles 31
1870 Monthey
Switzerland
Tel. +41 244 721 580
Fax +41 244 719 584
info@bolliger-mabillard.com

Bulletin No.:	2
Release Date:	June 1, 2007
Effective Date:	June 1, 2007
Supercedes:	
Issued by:	A. Pinizzotto
Checked by:	W. Bolliger
Page:	1 of 4

SAFETYALERT

Affected Park:
Affected Ride:
Ride Name:

Drawing No: SC-033-101
Item No:

Abstract of Issue:
Inspection of the safety harnesses weldments as per Detail of Issue.

Reason for Release:
Cracks were discovered on several harnesses.

Action to be taken:

- 1) Visual and magnetic particle inspection of the safety harnesses in the area shown in the Detail of Issue.
- 2) Harnesses presenting indication must be repaired or replaced according to the Detail of Issue criteria.
- 3) Seats with defective harnesses must not be operated until their repair or replacement.

Completion:

- visual inspection : immediately
- magnetic particle testing : within a week

Further inspections:

Repaired harnesses: daily visual inspection of the weldments during the 2007 season. Then, visual inspection on a weekly basis as indicated in the Maintenance Manual.

Other harnesses: weekly visual inspection of the weldments as indicated in the Maintenance Manual.

Detail of Issue:



Indication found

⇒ harness can be repaired if the indication is smaller than 25 mm (1 inch) in length. Harness presenting larger indication must be rejected and replaced.

SAFETY ALERT

Detail of Issue: Visual and magnetic particle inspection of the harness weldment

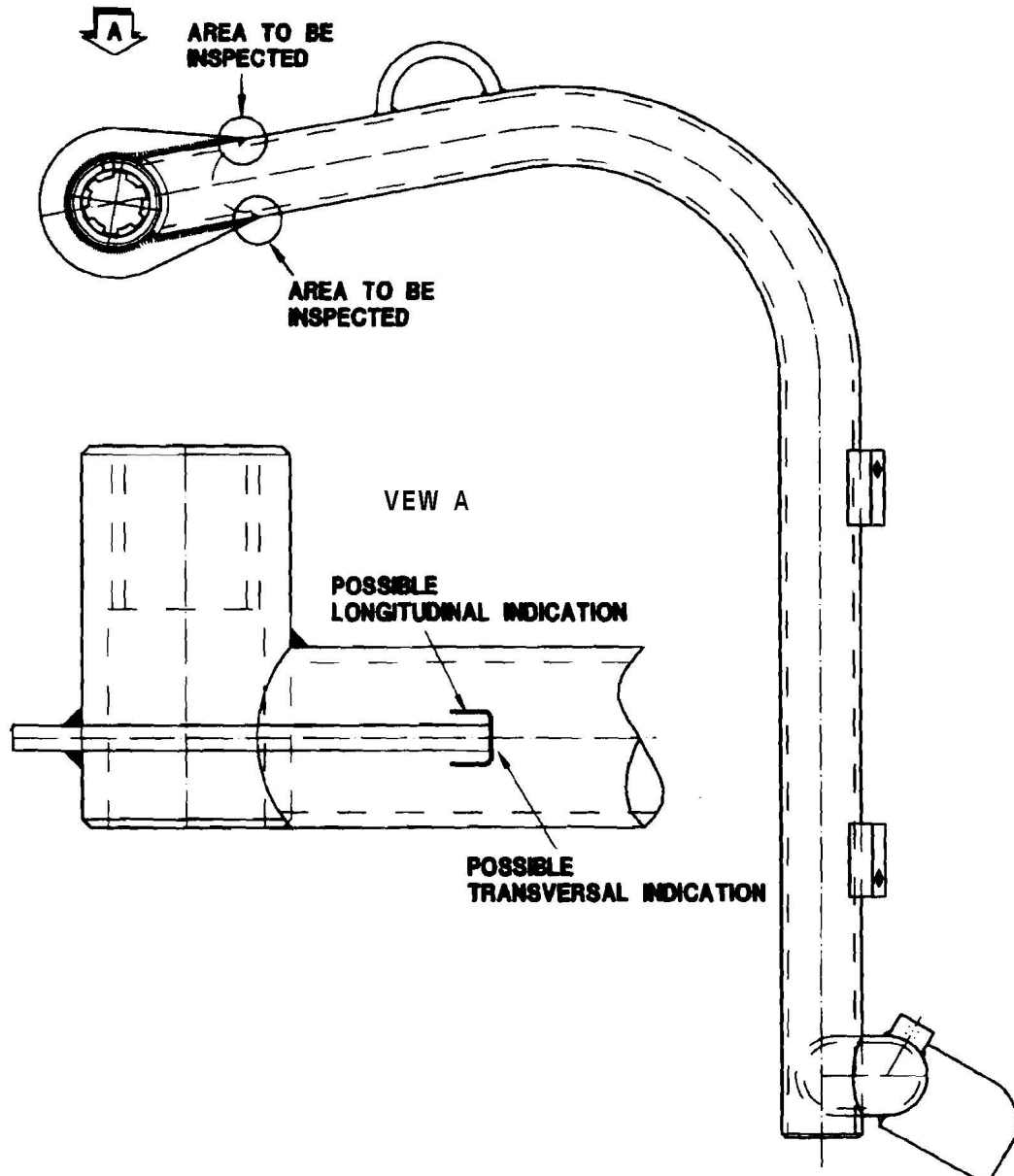

Bulletin No.:	2
Release Date:	June 1, 2007
Effective Date:	June 1, 2007
Supercedes:	
Issued by:	A. Pinizzotto
(Checked by	W Bolliger
Page:	3 of 4

SAFETY ALERT

Detail of Issue: Transversal indication – Repair procedure

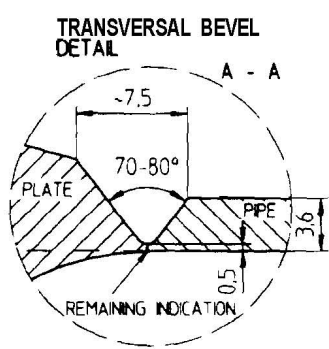
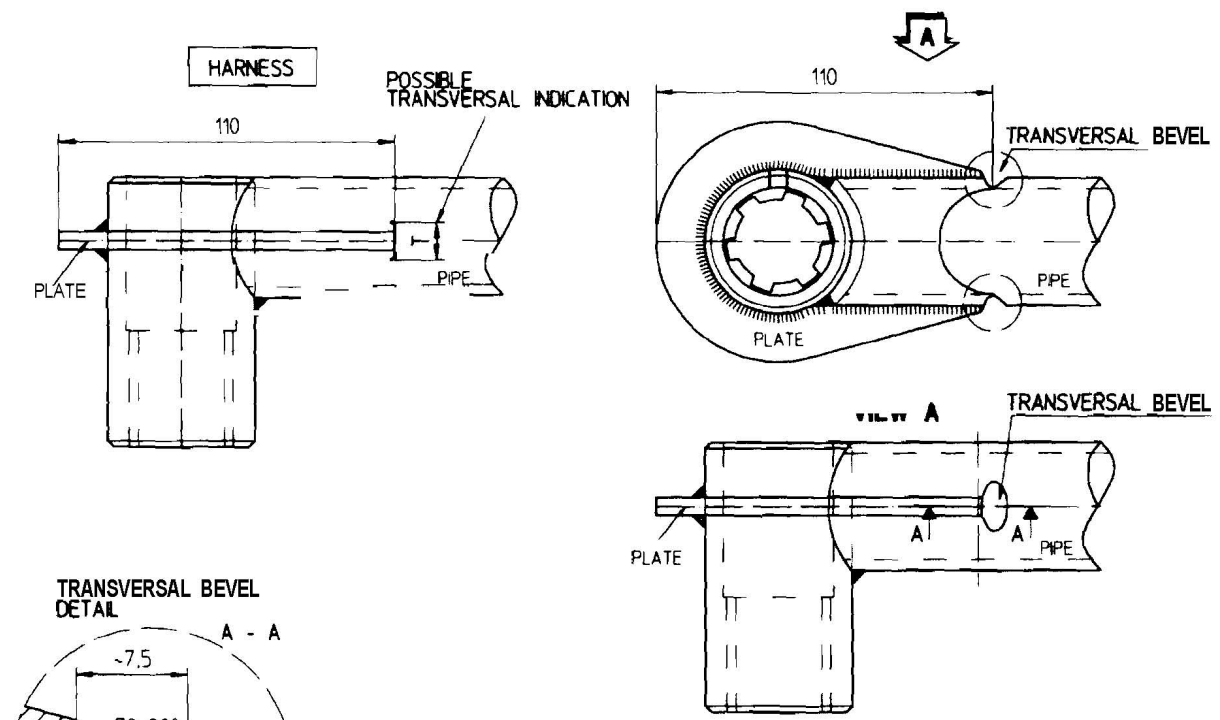

- GRIND GENTLY THE HARNESS PIPE IN ORDER TO OBTAIN THE BEVEL 'T' AS SHOWN IN VIEW A-A. TAKE CARE TO NOT 'PERFORATE' THE HARNESS PIPE (NOMINAL THICKNESS 3.6 mm). USE A ROTARY FILE WITH RADIUS END TO NOT GENERATE TRANSVERSAL 'CUTS' IN THE HARNESS PIPE. BEVEL SHOULD REMAIN AS SMALL AS POSSIBLE.

IF THE INDICATION VALUE 'T' IS LARGER THAN 25 mm (1 INCH) THEN THE HARNESS MUST BE REJECTED

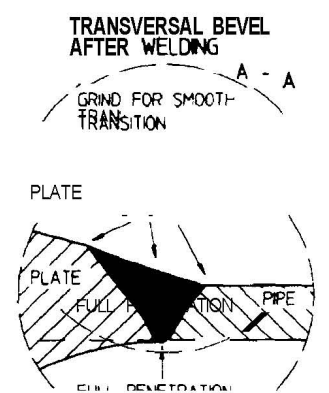

- REWELD USING THE TIG PROCESS (FILLER METAL ER 70 5-31 WITH THE FIRST LAYER MAKE SURE TO FUSION THE REMAINING INDICATION AND TO GUARANTEE A FULL PENETRATION (HARNESS MATERIAL IS ASTM A 572 - GRADE 501)
- INSPECT THE FIRST LAYER WITH MAGNETIC PARTICLE
- FINISH WELDING USING TIG PROCESS
- FINAL GRINDING TO ENSURE A SMOOTH TRANSITION
- FINAL NDT INSPECTION
- TOUCH UP PAINT

SAFETY ALERT

Detail of issue: Repair procedure in case of longitudinal indication

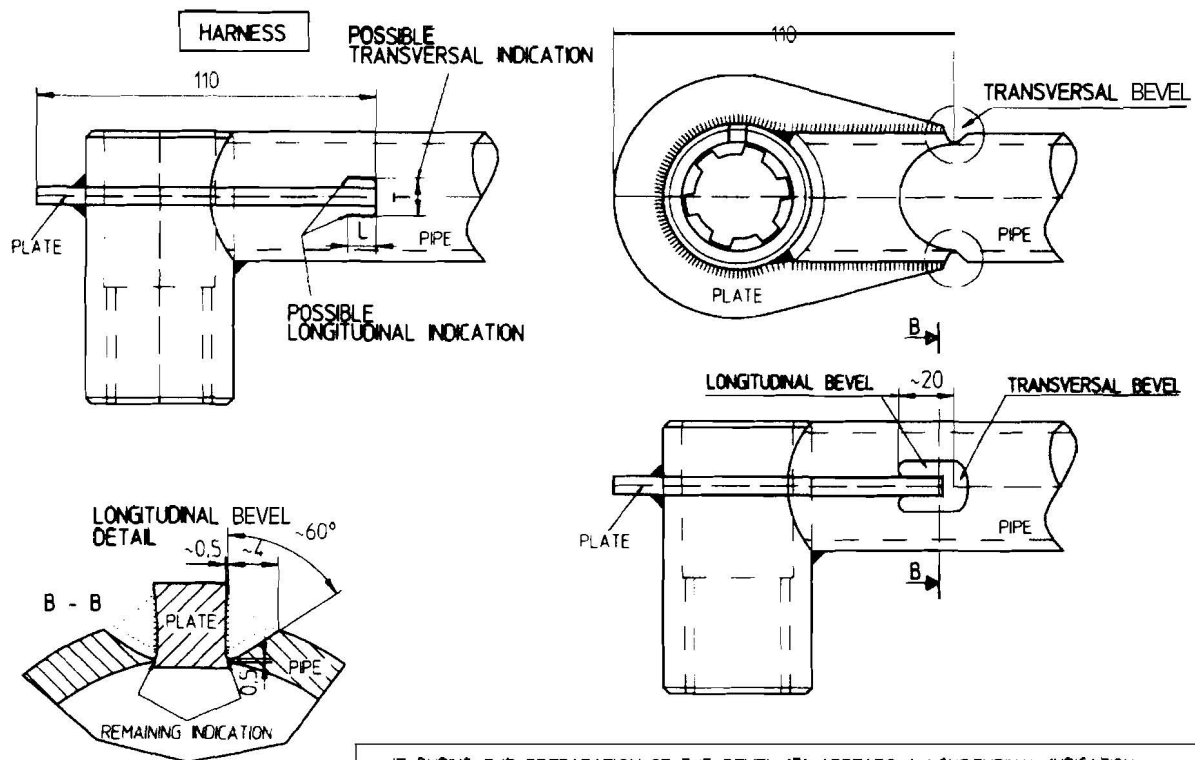

- IF DURING THE PREPARATION OF THE BEVEL "T" APPEARS A LONGITUDINAL INDICATION THEY GRIND GENTLY TO OBTAIN THE BEVEL "L" AS SHOWN IN VIEW B-B THE BEVEL "L" MUST BE AT LEAST 20 mm LENGTH TAKE CARE TO NOT "PERFORATE" THE HARNESS PIPE (NOMINAL THICKNESS 3.6 mm)
- REWELD USING THE TIG PROCESS (FILLER METAL ER 70 S-3) WITH THE FIRST LAYER MAKE SURE TO FUSION THE REMAINING INDICATION AND TO GUARANTEE A FULL PENETRATION (HARNESS MATERIAL IS ASTM A 572 - GRADE 501)
- INSPECT THE FIRST LAYER WITH MAGNETIC PARTICLE
- FINISH WELDING USING TIG PROCESS
- FINAL GRINDING TO ENSURE A SMOOTH TRANSITION
- FINAL NDT INSPECTION
- TOUCH JP PAINT

